

Sagola 6000X Air Heater



The Sagola 6000X Air Heater provides an optimal surface quality finish, whilst maintaining a constant temperature in the compressed air which reduces its relative humidity. This avoids condensation problems in cold and wet environments as required for the application of certain types of products. To ensure the Sagola 6000X is safe to touch, it has a cool touch case where the cold air enters the pressurised chamber cooling the outer shell of the equipment, keeping it isolated from the hot chamber inside.

Features

- Temperature stability both in the compressed air and the final painting elements such as hose and spray gun.
- Stable painting process in areas with large temperature changes between day and night, winter and summer.
- Constant working temperature.
- Compact and robust.
- Digital temperature display.
- Cold touch, thermal insulation.
- Easy to use; power button and temperature controller.
- Out of the box installation.
- Lightweight and small; easy to locate.
- Right temperature in the spray gun almost immediately.
- Includes a insulated hose to get the maximum energy-performance.
- Designed to be fitted after Sagola 5000 and Sagola 4000 series air filtration systems and before the spray gun.

Components

1. Controls
2. Mains switch
 - 3a. Red LED (Heating)
 - 3b. Green LED (Ready)
4. Temperature sensor
5. Flow meter
6. Cold air chamber (depressurised)
7. Hot air chamber (pressurised)
8. Air inlet (from air filter)
9. Air outlet (hose)
10. Electrical connection
11. Wall mounting bracket

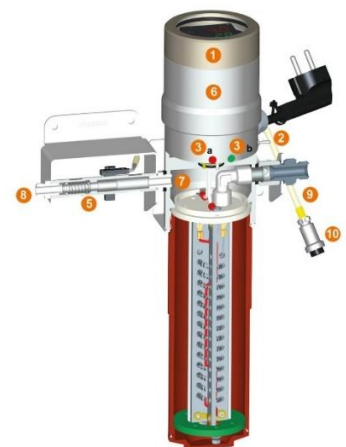



Technical Specifications

Power	110-240V
Maximum Consumption	800 watt
Maximum working pressure	7bar
Maximum flow at 7bar	750l/min
Recommended Temperatures:	
Clearcoat	40-60°C
Waterborne basecoat	30-50°C
Solvent based basecoat	30-40°C
Dimensions	405 x 92 x 255mm
Weight	3.6kg

Packing List

Packing List	Sagola 6000X Air Heater with 11m Heated Hose & UK Plug Adaptor (UK only)
--------------	--

Part Number

Sagola 6000X Air Heater 220V – 50Hz EU	
	Voltage: 220V - 50Hz
	Part Number: 10780102
Sagola 6000X Air Heater 110V – 60HZ USA	
	Voltage: 110V – 60HZ
	Page Number: 10780104
Sagola 6000X Air Heater; 220 - 240V, 50Hz UK	
	Part Number: PT10780102UK

Accessories

Description	Part Numbers
Sagola 6000X Heated Hose, 11m; EU/UK: 220 - 240V, 50Hz	56414030
Sagola 6000X Heated Hose, 11m; US: 110 - 130V, 60Hz	56414031